

The Aura family of Noiseless InGaAs™ APDs is designed to boost the performance of LIDAR, range finding, optical time domain reflectometry (OTDR), optical coherence tomography (OCT), and other optical systems requiring high-performance infrared sensing from 900 - 1650 nm wavelength.

The Aura series is available with a 30, 80 or 200 μm diameter optical aperture.

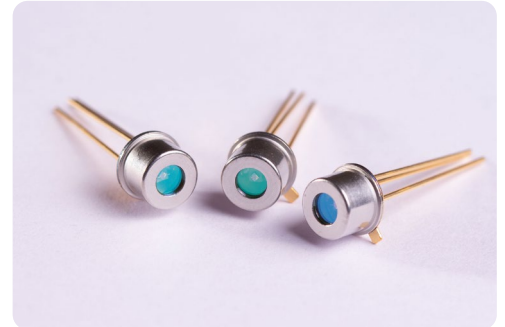

Benefits

- ✓ Up to 50% greater detection range.
- ✓ Up to 12 × higher resolution in imaging.
- ✓ Up to 30% smaller systems.
- ✓ Up to 40% lower system cost.

Features

- ✓ Up to 12 × more sensitive than traditional InGaAs APDs.
- ✓ Can be operated at APD gain of >120.
- ✓ 10 × lower temperature coefficient of breakdown eliminates temperature drift compensation.
- ✓ Inherently fast impulse response.
- ✓ Fast overload recovery at high gain and high signal for reliable secondary pulse detection.
- ✓ Built to MIL-STD-883 for durability.
- ✓ Available as bare die, TO-46, fibre pigtail, SMD or chip on submount packages.

Note: The term Noiseless InGaAs™ is used to describe Phlux's patented compound semiconductor technology that is used to manufacture APDs with an excess noise factor low enough to enable an APD gain of over 100 without SNR deterioration.

Absolute minimum/maximum ratings

Parameter	Condition	Min	Max	Unit
Storage temperature		-40	+125	$^{\circ}\text{C}$
Operating temperature		-40	+85	$^{\circ}\text{C}$
Forward current			10	mA
Reverse current			1	mA
Reverse voltage			-68	V
CW optical power	$\lambda = 1550 \text{ nm}$		0	dBm
Damage threshold ⁽¹⁾	$\lambda = 1535 \text{ nm}$		30	MW/cm ²

Electrical and optical characteristics at 25 $^{\circ}\text{C}$

Parameter	Condition	Min	Typical	Max	Unit
Optical window			80		μm
Spectral range			0.95 - 1.7		μm
Responsivity, R	$\lambda = 1550 \text{ nm}, M = 1$	0.94	0.98	1.02	A/W
Dark current, I_{dark}	$M = 10$	3	6	10	nA
Cut-off frequency	$M = 10$		1.8		GHz
Capacitance	$M = 10$	0.5	0.6	0.8	pF
Operating voltage, V_{op}	$M = 10$	-50	-55	-60	V
Breakdown voltage, V_{br}		-60	-65	-70	V
Temperature coefficient of Breakdown voltage, C_{bd}			20		mV/ $^{\circ}\text{C}$
Excess noise factor, F	$M = 10$		1.08		
	$M = 40$		1.86		
Spectral noise current, i_{noise} ⁽²⁾	$M = 10$		0.1		pA/Hz ^{0.5}
	$M = 40$		0.7		
Noise equivalent power ⁽³⁾	$M = 10$		11.1		fW/Hz ^{0.5}
	$M = 40$		16.8		

Typical figures of electrical and optical characteristics at 25 °C

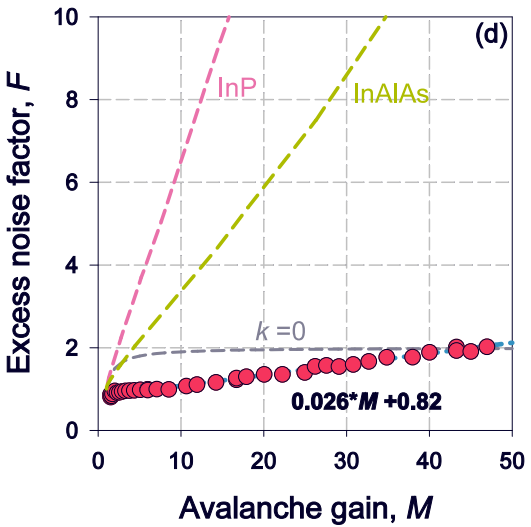
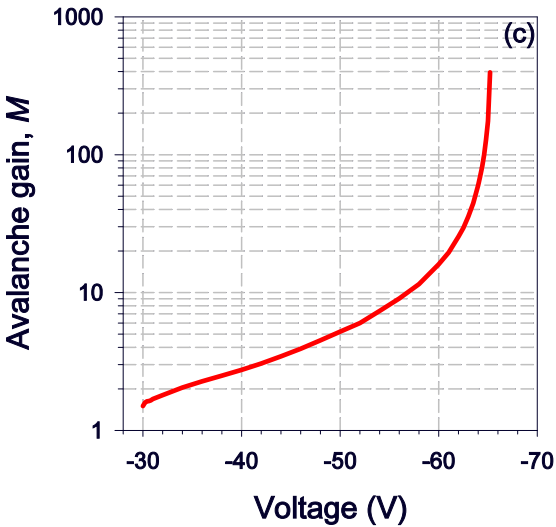
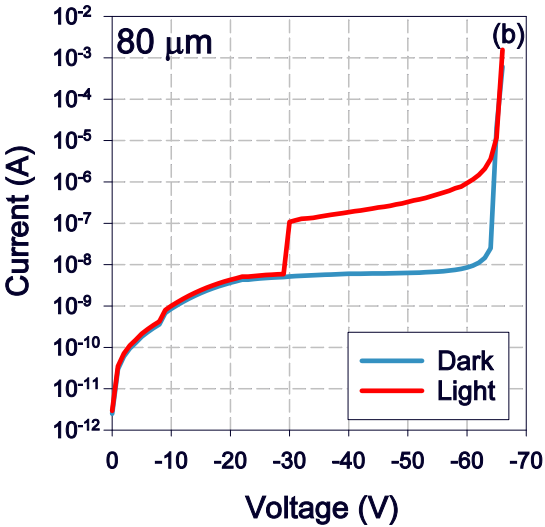
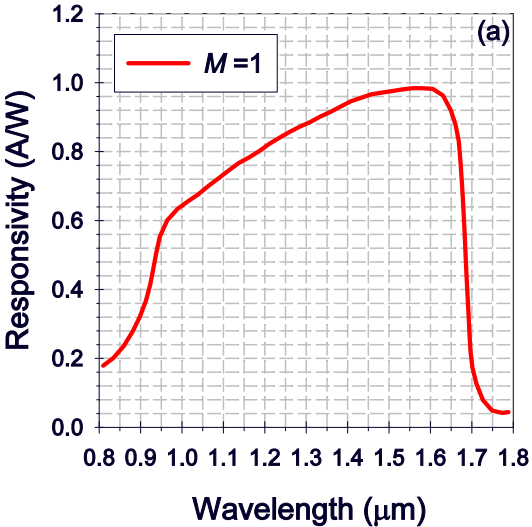

Typical figures of temperature dependent characteristics

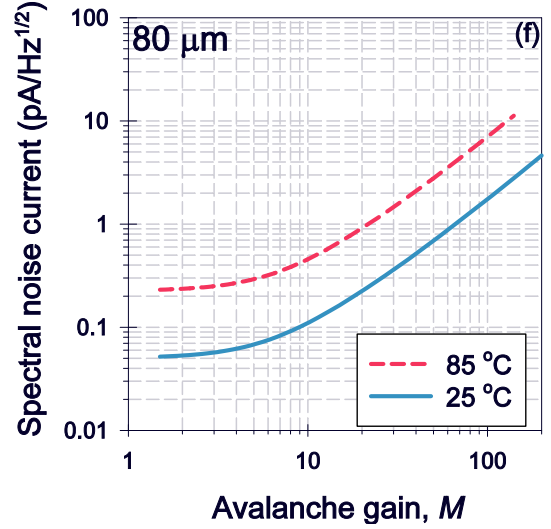
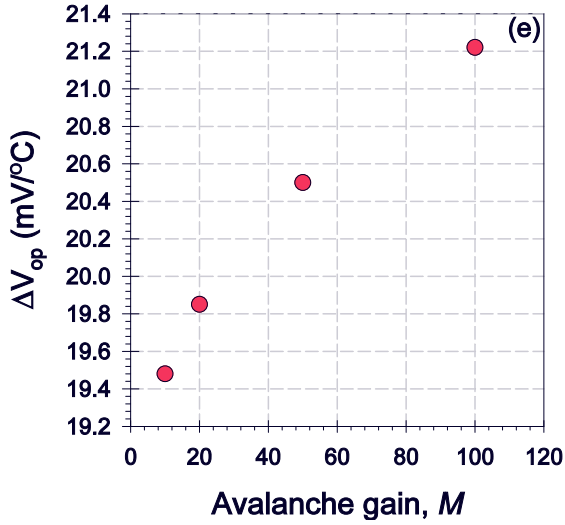

- (1). The experimental set-up for measuring the damage threshold consisted of an APD DC coupled to the TIA. The APD had a current limiting resistors and capacitors on the high voltage bias input. The laser was a 1535 nm diode-pumped solid-state laser source with a 4 ns optical pulse width and 10 Hz repetition rate.
- (2). The spectral noise current, i_{noise} was obtained by the following equation,

$$i_{noise} = \sqrt{2q(I_{surf} + I_{bulk}M^2F)}$$

where q is the electron charge, M is the avalanche gain, F is the excess noise factor. The surface component, I_{surf} , and bulk component, I_{bulk} , of dark current, I_{dark} , were extracted by the equation, $I_{dark} = I_{surf} + M \cdot I_{bulk}$.

- (3). The theoretical noise equivalent power (NEP) values can be calculated using the equation below,

$$\begin{aligned} NEP &= \frac{1}{R_m} (\sqrt{i_{noise}^2 + \sigma_{amp}^2}) \\ &= \frac{1}{R_m} (\sqrt{2q(I_{surf} + I_{bulk}M^2F) + \sigma_{amp}^2}) \end{aligned}$$

where R_m is the multiplied responsivity value ($R \cdot M$), σ_{amp} is the external amplifier input noise. The NEP values at $M = 10$ & 40 were calculated by excluding the external amplifier input noise σ_{amp} .

Additional technical information available upon request.

Package Mechanical Dimensions

CHIP ON SUBMOUNT

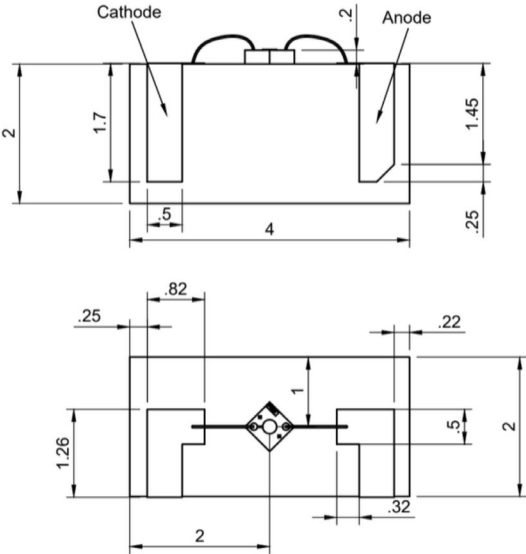

Diagram units in mm

- Die attach = Low outgas epoxy**
- Ceramic = 96% Alumina**
- Solder pad metal = Gold**
- Metal thickness = 10 μm ($\pm 2 \mu\text{m}$)**

TO-46 3 PIN (HIGH PROFILE)

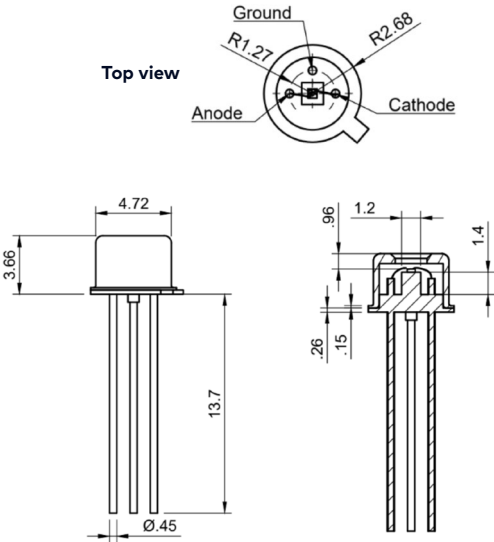
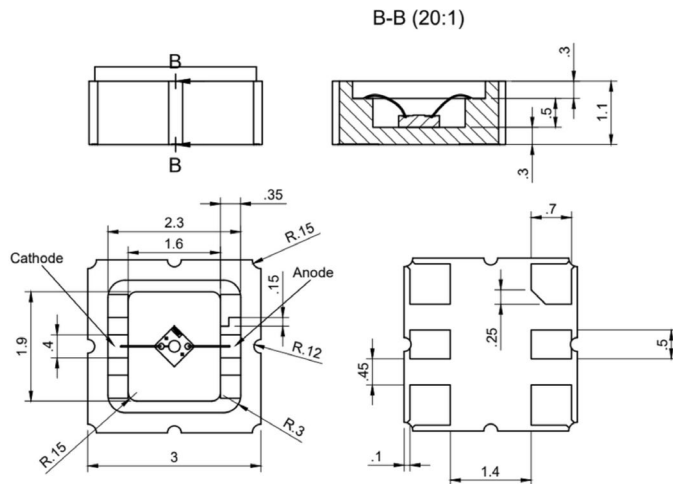

Diagram units in mm

- Pin metal = Gold**
- Optical window AR coated with >98% transmission at 1550nm**

Package Mechanical Dimensions

SMD



Please note, product specifications are subject to change without prior notice.